

2023

OPTIWATT 4,86kWp

Installation Manual

(Northern Hemisphere)

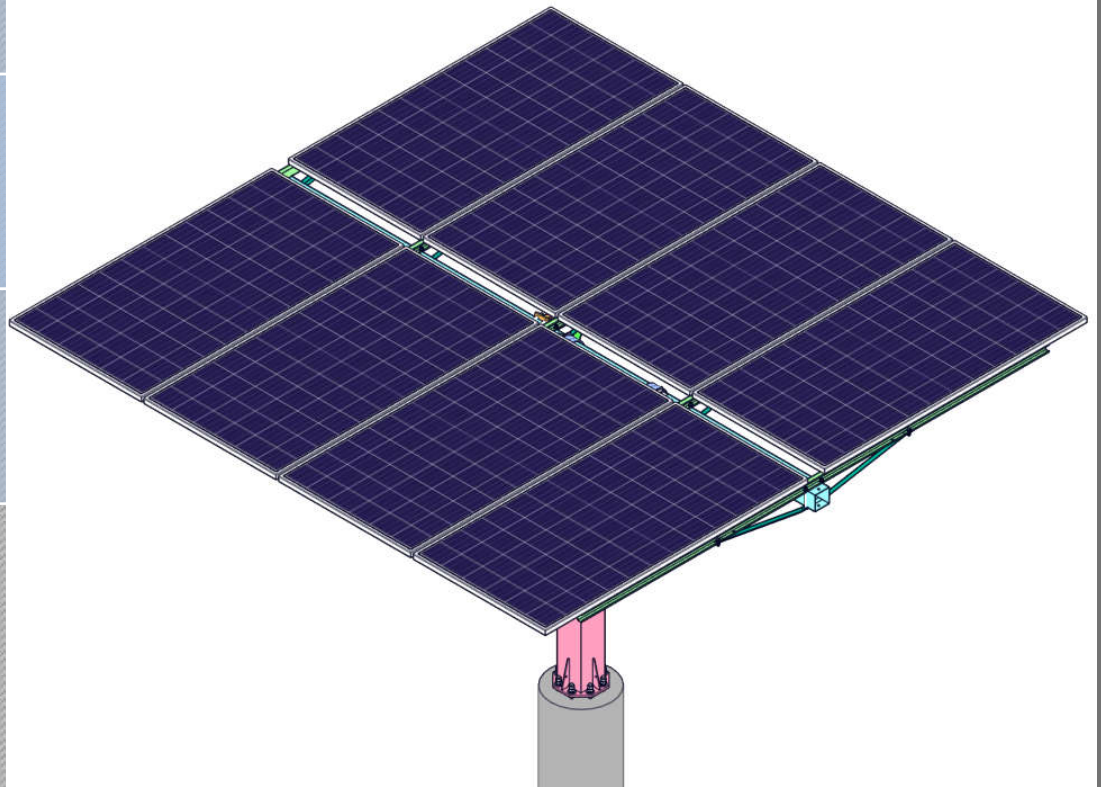

INTRODUCTION

Thank you for purchasing this solar tracking system designed and manufactured by ~~Shandong Lihong New Energy Tech. Co., Ltd.~~, we will wholeheartedly to provide first-class product and service for you.

This manual provides important information about constructing the necessary concrete foundation, and the assembly of the tracking mechanism. Be sure to retain this manual for future reference. Read it carefully & thoroughly **before** starting the installation. We and our re-sellers accept no responsibility for your failing to follow these instructions. Use proper tools and follow good safe work practices to avoid injury during assembly. Always wear safety helmet to prevent head injury.

We own IPR (**Intellectual Property Rights**) on the solar tracking system we manufacture and distribute, with more than 40 patents at home and abroad, any patent infringements will be prosecuted to the fullest extent of the law.

CONTENTS

I. ZRD-12 tracking system structure chart.....	1
II. Connecting screws and clamps details	2
III. Tools required for installation	3
IV. Concrete foundation.....	3
V. Installation of ZRD-12 tracking system.....	8
5.1 Installation of vertical pole	8
5.2 Assembly of L-shaped bracket & center beam.....	9
5.3 Installation of L-shaped bracket & Elevation linear actuator.....	10
5.4 Installation of Azimuth Linear Actuator	12
5.5 Installation of supporting beams	13
5.6 Installation of control unit	14
5.7 Installation of solar panels.....	15
5.8 Connect control unit circuit	16
VI. Crane hoisting	18
VII. Control unit debugging.....	19
VIII. Daily operation and maintenance – Important!	20
IX. Quick trouble shooting	21
X. Spare parts replacement	22
10.1 Gear motor replacement	22
10.2 Control box replacement	22

Part I. ZRD-12 Tracking System Structure Chart

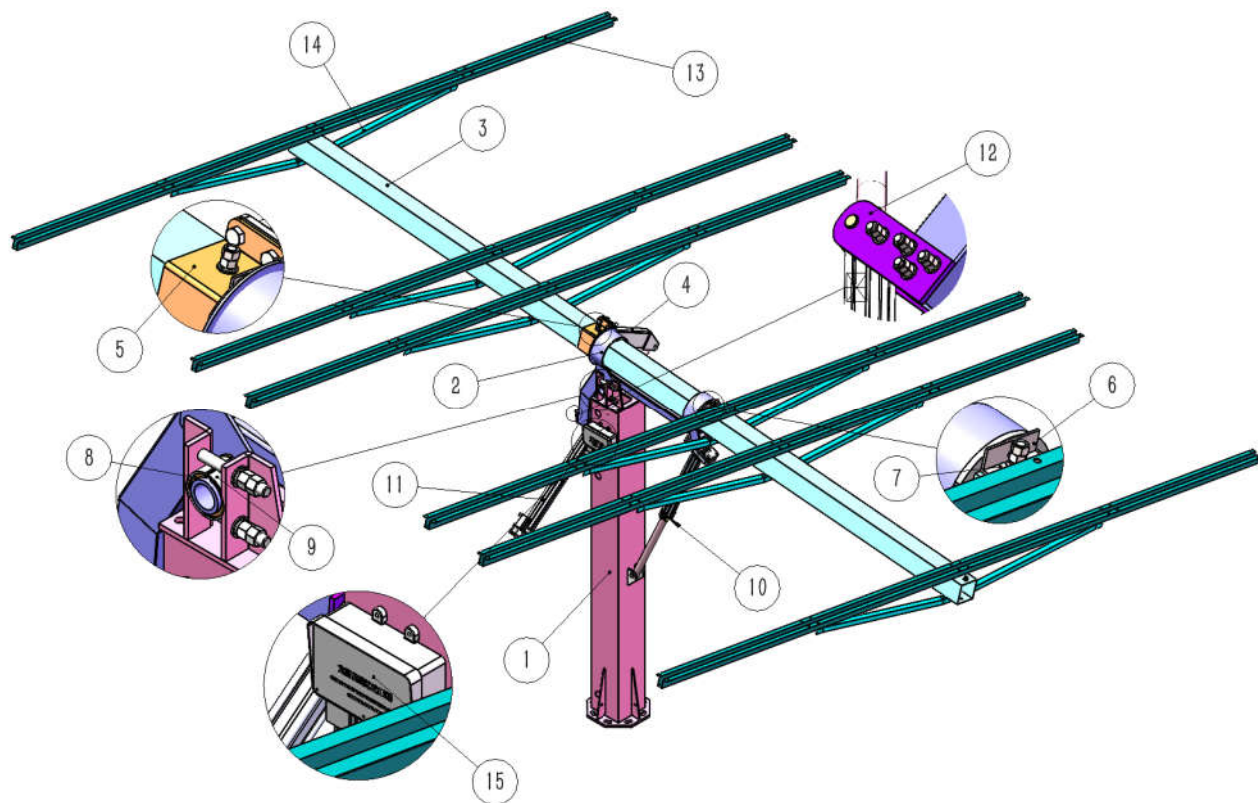

System structure chart

Main parts of ZRD solar tracking system

Item	Description	Weight (kg)	Total Weight	Dimension(mm)	Quantity
1	Vertical pole	44.5	44.5	2000*200*200*2.5	1
2	L-shaped bracket	15.7	15.7	770*194*5	1
3	Center beam	45.8	45.8	120*120*2.5*5000	1
4	Swing arm	5.6	5.6	380*100*50*3.5	1
5	Swing arm fixing plate	2.2	2.2	212*110*120	1
6	Plastic bearing	0.2	0.8	φ 120	4
7	Plastic bearing limit	0.25	0.5	36*50 angle steel	2

8	Plastic shaft sleeve	0.1	0.2	φ 60*45	2
9	Steel shaft sleeve	0.4	0.8	70*5	2
10	Elevation linear actuator	7.0	7.0	L=940mm	1
11	Azimuth linear actuator	7.5	7.5	L=985mm	1
12	Azimuth linear actuator seat	0.9	1.8		2
13	Supporting beam	7.9	47.4	55*32*1.8*4595	6
14	Inclined strut	2.8	16.8	34*30*1.8*2200	6
15	Control unit	1.0	1.0		1
Total			198		

Part II. Connecting Screws and Clamps Details

Item	Specification	Quantity
S0	M22 double nuts, 2 flat washers, spring washer	8 sets
S1	M14*160 bolt, double nuts, 2 flat washers, spring washer	2 sets
S2	M16*120 bolt, double nuts, 2 flat washers, spring washer	4 sets
S3	M16*60 bolt, double nuts, 2 flat washers, spring washer	4 sets
S4	M12*120 bolt, double nuts, flat washer, spring washer, 2 plastic washers	4 sets
S5	φ 16*125 axis pin, flat washer, split pin, small plastic pipe	1 set
S6	φ 16*85 axis pin, flat washer, split pin	2 sets
S7	M12*160 bolt, double nuts, flat washers, spring washer, rectangular plate	12 sets
S8	M12*30 bolt, nut, 2 flat washer, spring washer	13 sets
S9	M8*20 bolt, nut, 2 flat washers, spring washer	48 sets
S10	M5*23 self-tapping screw	3 sets

For 'double nuts', please fasten the first nut, then fasten the second nut.

Part III: Tools Required for Installation (Self-prepared by users)

No.	Tools	Spec.	Quantity	Remarks
1	Open spanner	13/14	2	M8 screws
2	Open spanner	17/19	2	M12 screws
3	Open spanner	20/22	2	M14 screws
4	Open spanner	22/24	2	M16 screws
5	Open spanner	32/34	1	M22 screws
6	Adjustable spanner	10 Inch	2	Crescent adjustable wrench
7	Screwdriver	3#	1	Electric debugging (flat head or cruciform)
8	Rubber Hammer		1	Facilitate the installation
9	Double ladder or Scaffolding		2	or use small crane

Part IV. Concrete Foundation

Materials Preparation

Marks	Description	Material	Quantity
①	Foundation bolt	M22	8
②	Fixture template	---	1
③	Foundation (above ground)	C30 concrete	---
④	Foundation (below ground)	C30 concrete	---

1. Make 8 foundation bolts ①, one foundation bolt fixture template ② (using rigid material, only for positioning bolts, thickness is not important).

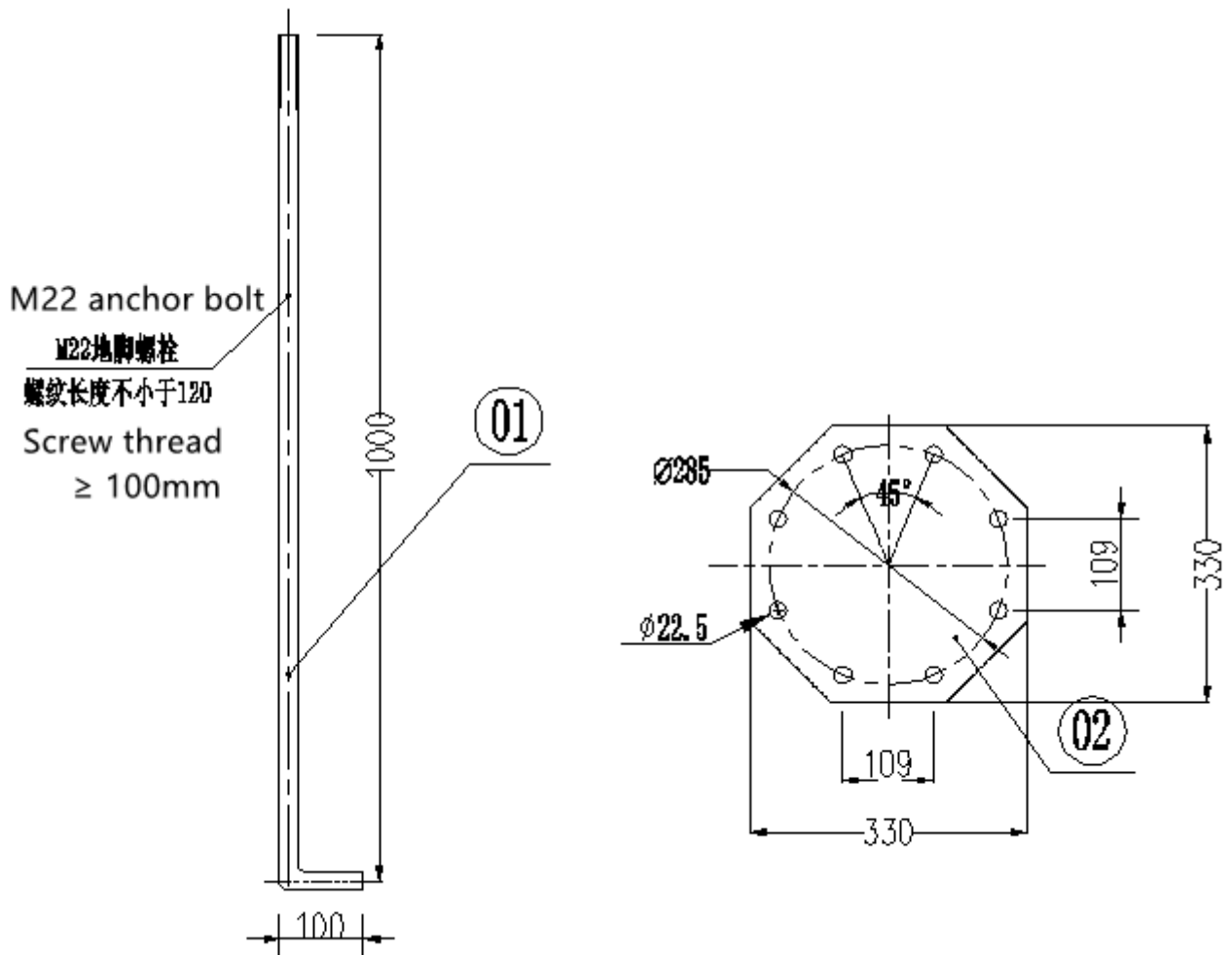

2. Position 8 foundation bolts ① with the fabricated fixture template ②, secure the bolts to foundation steel mesh grid (using $\Phi 8$ steel rebar). Confirm the east-west direction carefully, pour concrete foundation according to the dimensions shown in the following drawings, remove the fixture template ② after the concrete is cured. The solar tracking system installation can be carried out only AFTER the concrete is thoroughly cured.

(Covering the poured concrete with a plastic sheet will make it stronger, because it will dry out slower from sun exposure. To convert the dimensions from mm to inches divide by 25.4)

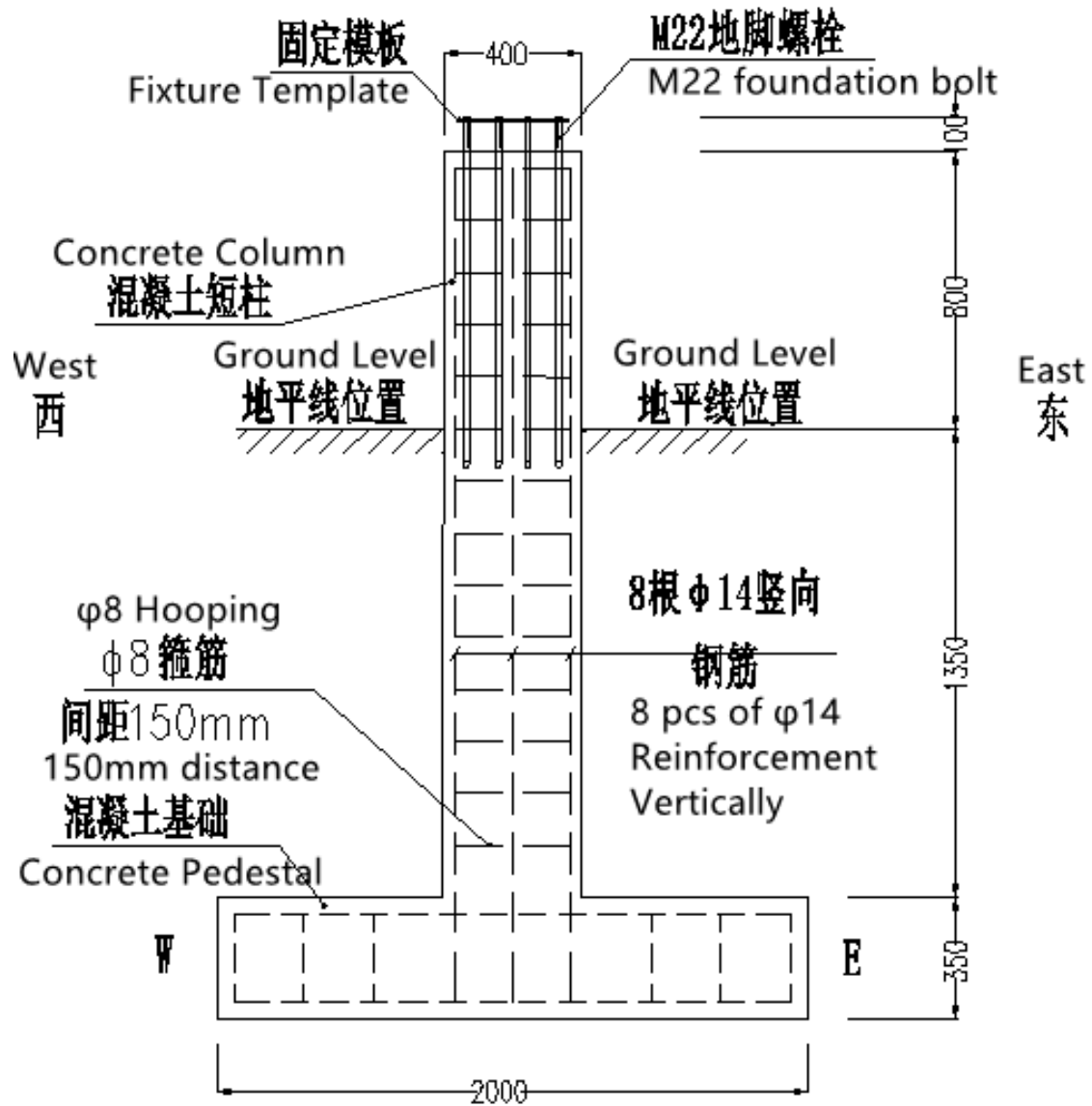

Foundation as viewed from the South

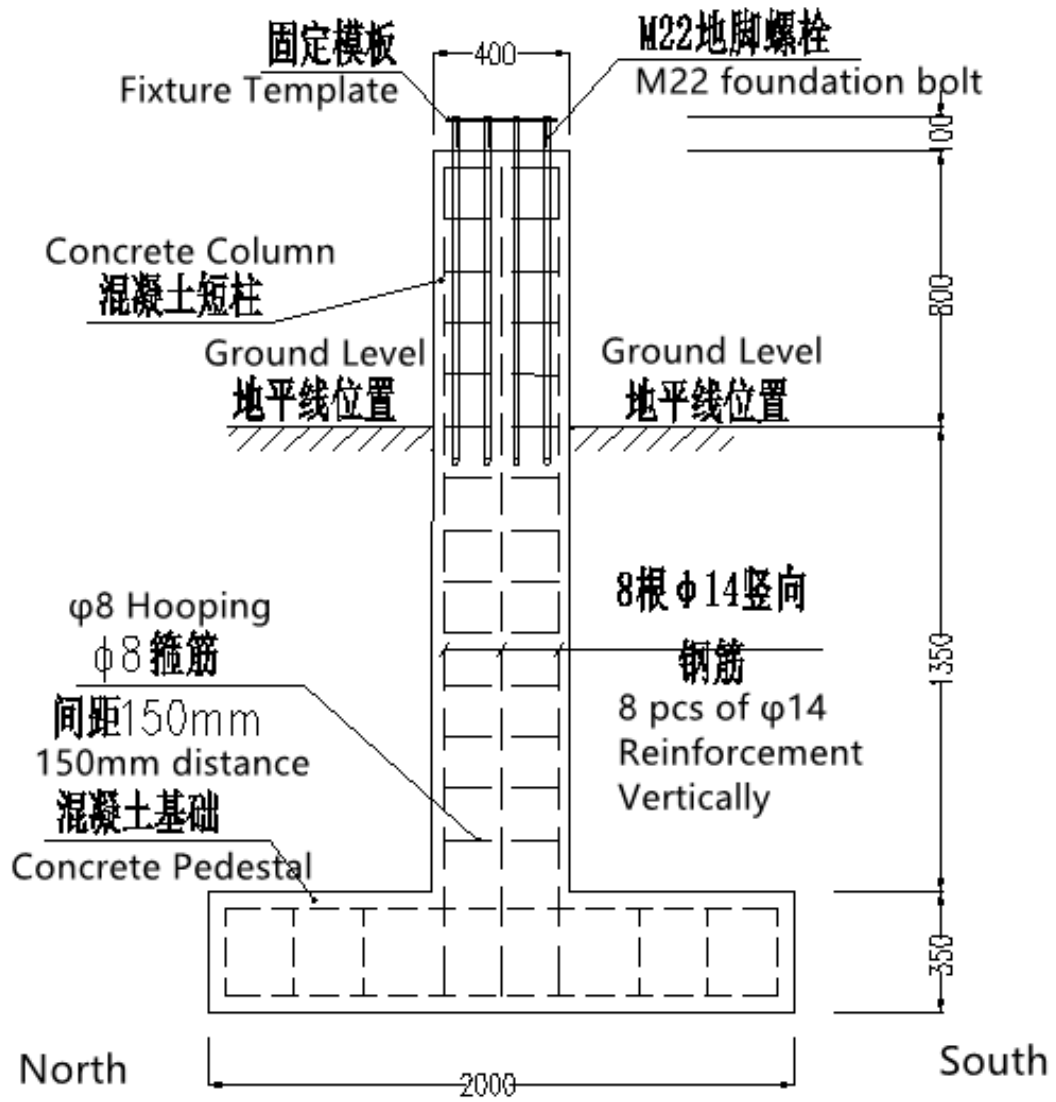

Foundation as viewed from the West

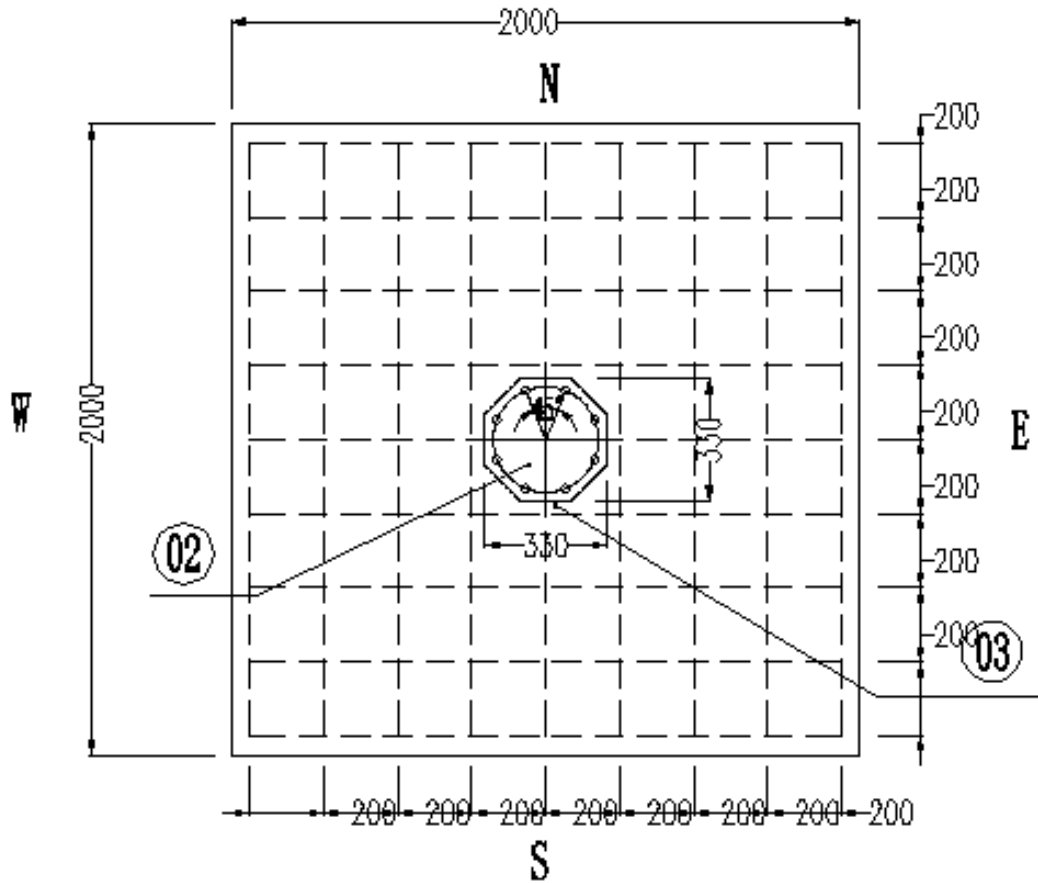

Foundation as viewed from Above

Note: **Foundation above the ground should be more than 800 mm**, exposed foundation bolts ① thread at least 100 mm. In order to ensure the verticality of tracking system pole, the top face of foundation shall be leveling with spirit level. The dimension and depth of the concrete foundation is just a guide, please design it for your local soil conditions and maximum wind speeds.

Concrete, foundation bolts ① and fixture template ② shall all be prepared by users. $\Phi 40$ mm conduit for electrical wires can be planned into the concrete foundation, used for threading PV lines, controller power lines, etc.

Part V. Installation of ZRD-08 Tracking System

5.1 Installation of Vertical Pole

Put the vertical pole ① on the concrete foundation, **verify the orientation of the vertical pole ①** to ensure the side with linear actuator seat is facing **South**, then put on flat and spring washers, secure with hardware ⑤0 (double nuts) to stabilize the vertical pole ①. There are three cable entrance holes on **west** side of the vertical pole ①.

South means the direction of the geographical longitude lines, it can be confirmed with gyroscope or compass (need to amend the geomagnetic declination, different sites, difference geomagnetic declination).

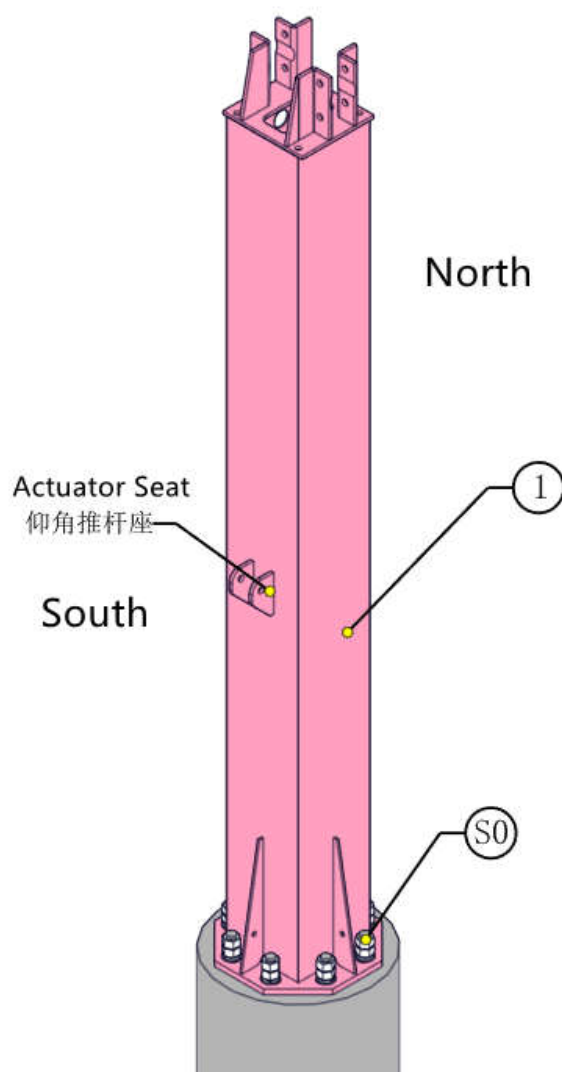

5.2 Assembly of L-shaped bracket & Center beam

Put the center beam ③ into the L-shaped bracket ②, **please pay attention to the direction of the center beam**. Then put two plastic bearing ⑥ into the **north** hoop of the L-shaped bracket (insert the plastic bearing from the **north** side), then fix the swing arm fixing plate ⑤ onto the center beam with hardware ⑤①, then fix the swing arm ④ onto swing arm fixing plate ⑤ with hardware ⑤③, and put two plastic bearing ⑥ into the **south** hoop of the L-shaped bracket (insert the plastic bearing from the **south** side). Then use hardware ⑤① to fix the plastic bearing limit ⑦ on the center beam. Installer may need to knock the plastic bearing into the hoop with hammer, this is for reducing shaking space.

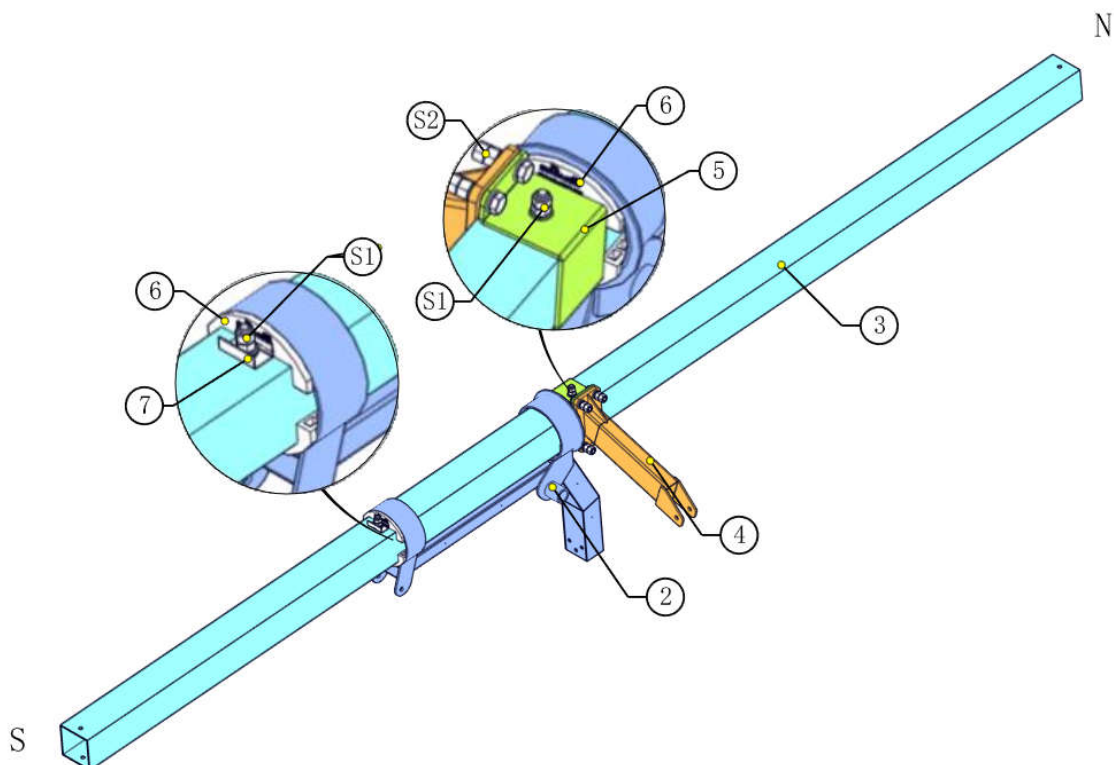

5.3 Installation of L-shaped bracket & Elevation linear actuator

Install two lower screws of hardware ② onto the top of vertical pole ①, do not fasten it for the time being. Put the plastic shaft sleeve ⑧ into the steel shaft sleeve ⑨, both openings are in same direction. Then affix the L-shaped bracket ② onto the vertical pole ①, put the plastic shaft sleeve and steel shaft sleeve onto the shaft of L-shaped bracket, the opening faces upwards, please pay attention to the direction of plastic shaft sleeve, then install the other two upper screws of hardware ②, tighten the four screws of hardware ②.

Note: Please pay attention to the direction of L-shaped bracket ②!

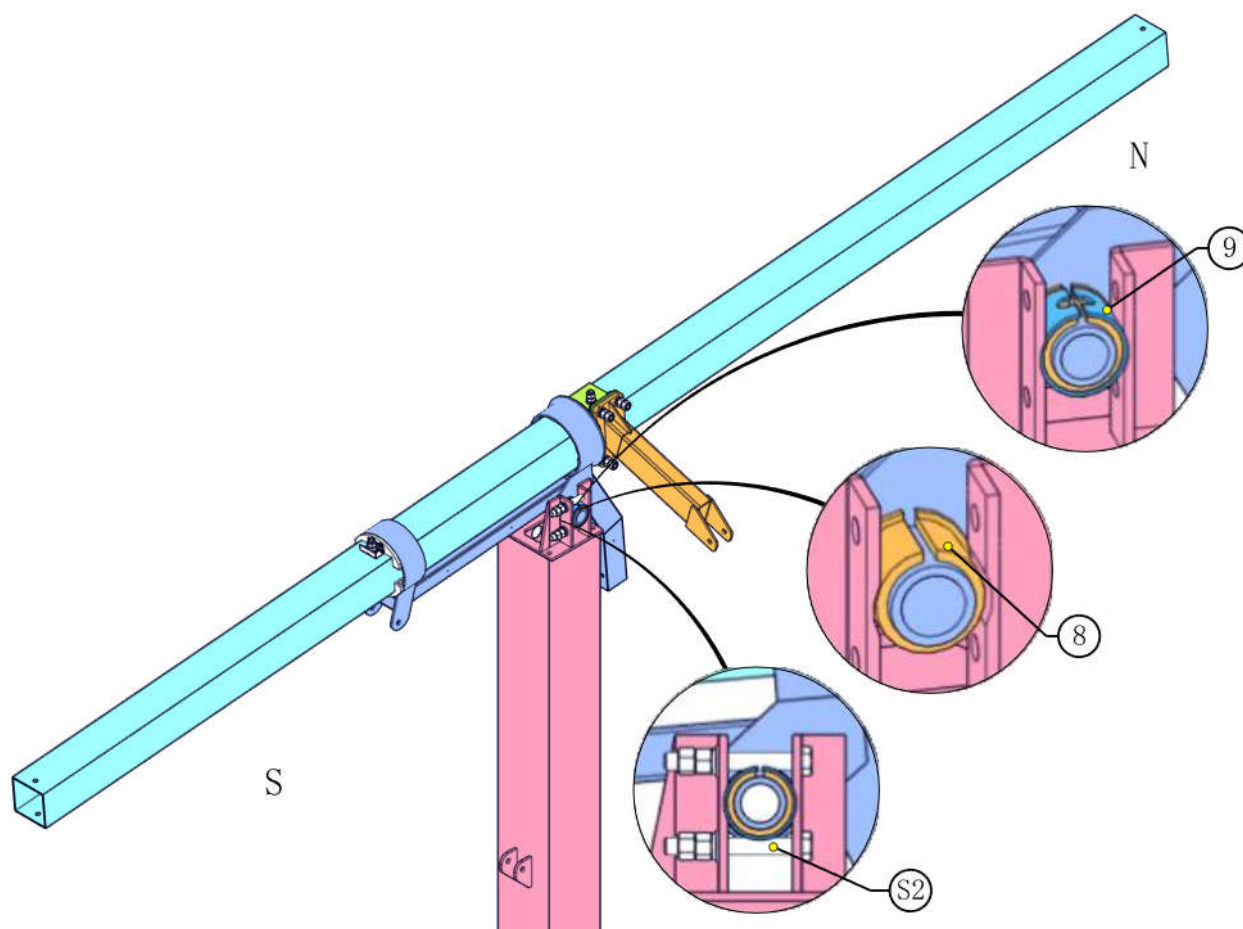

Fix **elevation linear actuator** ⑩ with **L-shaped bracket** ② with hardware ⑤. The motor is on top and **south** side. Put the plastic washers of hardware ⑤ as following drawing. Fix **elevation linear actuator** ⑤ with **vertical pole** ① with hardware ⑥, split the split pin. There are two kinds of linear actuators for each unit, do not mixture them up when installing them.

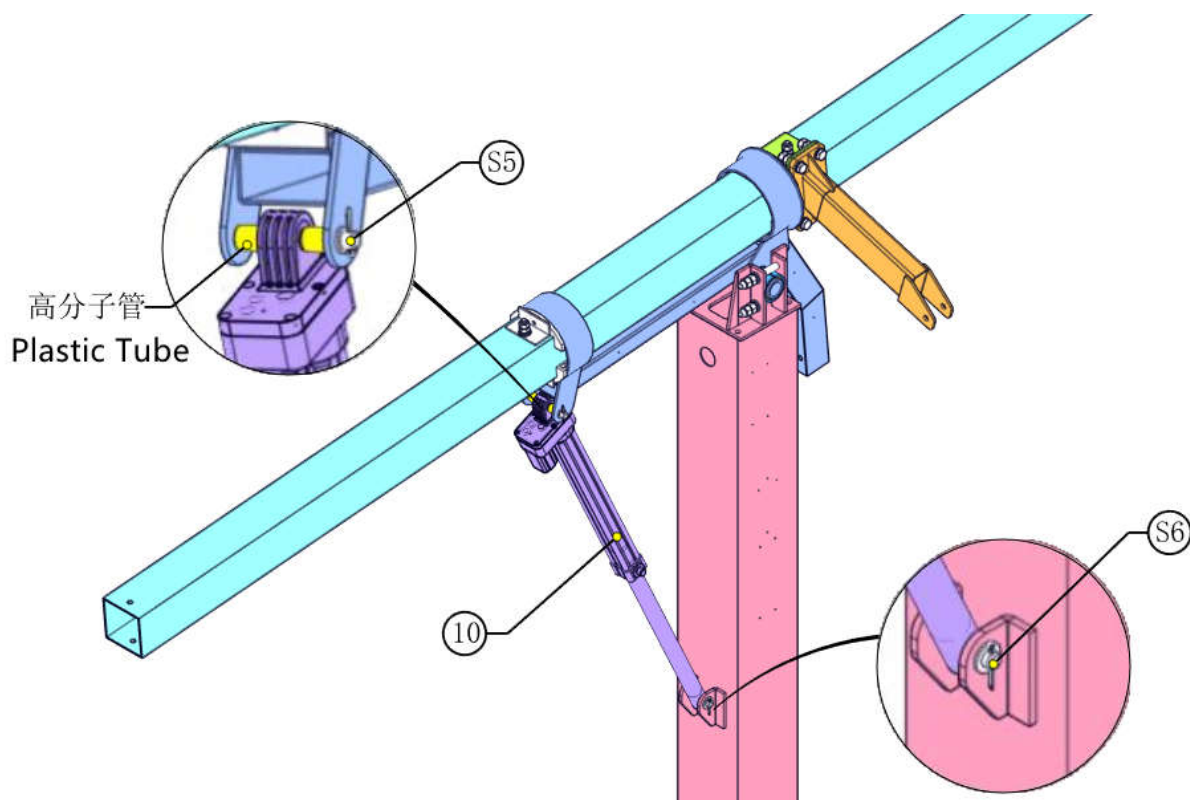
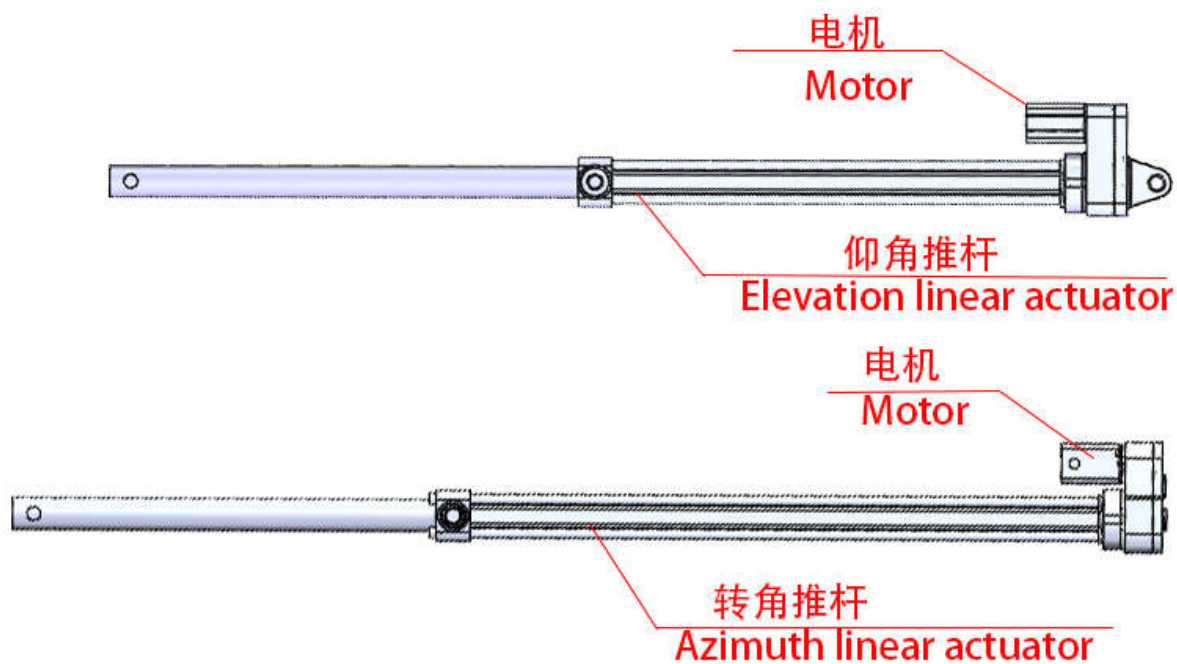

5.4 Installation of Azimuth Linear Actuator

Fix the azimuth linear actuator ⑪ to L-shaped bracket ② with azimuth linear actuator seat ⑫ and hardware ④. Please pay attention to the direction of the motor. The nuts of hardware ④ should be on the **north** side. Put the plastic washers of hardware ④ between the azimuth linear actuator seat and azimuth linear actuator. Fix azimuth linear actuator ⑫ to swing arm with hardware ⑥, the split pin of hardware ⑥ should at the **south** side of swing arm, split the split pin. **Adjust the position of swing arm and swing arm fixing plate slightly, make the linear actuator at the center position of swing arm.**

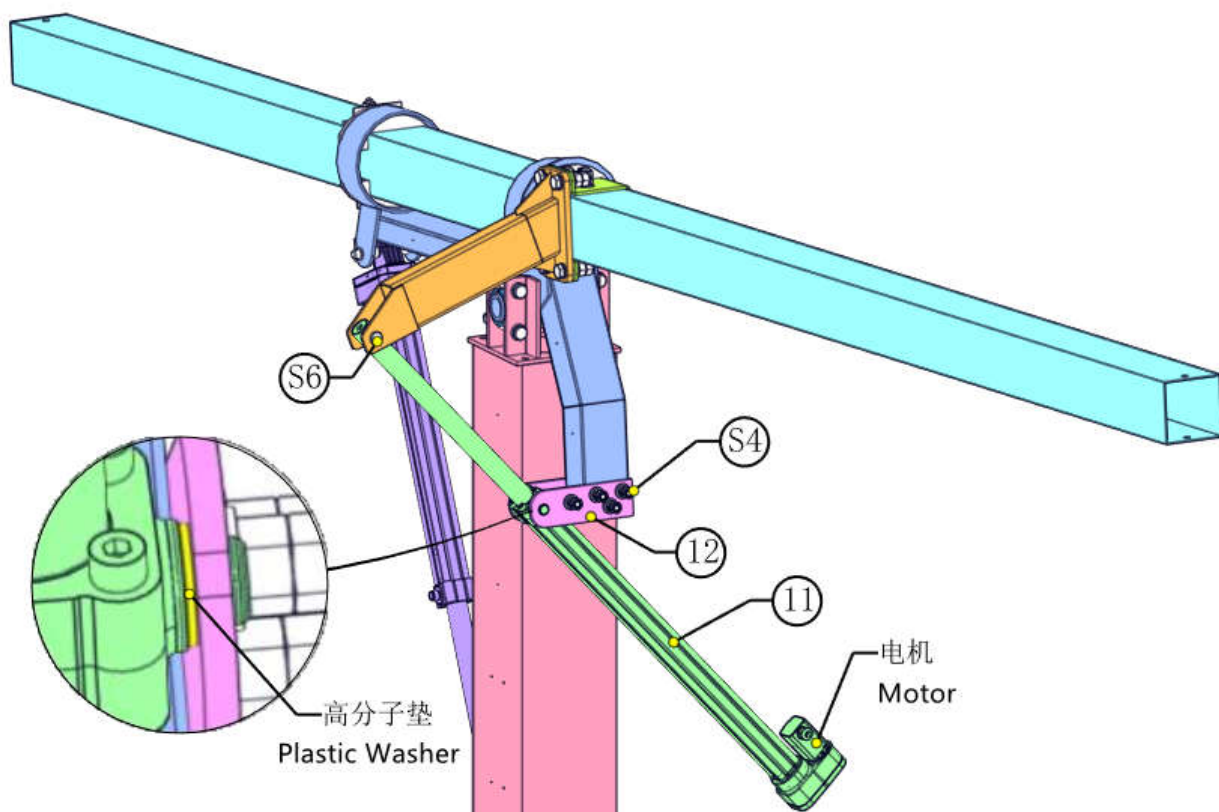

5.5 Installation of Supporting Beam & Inclined Strut

Fix the first **supporting beam** ⑬ and **inclined strut** ⑭ onto **center beam** with **hardware** ⑦ & ⑧ as distance in following drawing. Then install a M12*30 bolt of hardware ⑧ at the **south** end of **center beam** for anti-slip purpose.

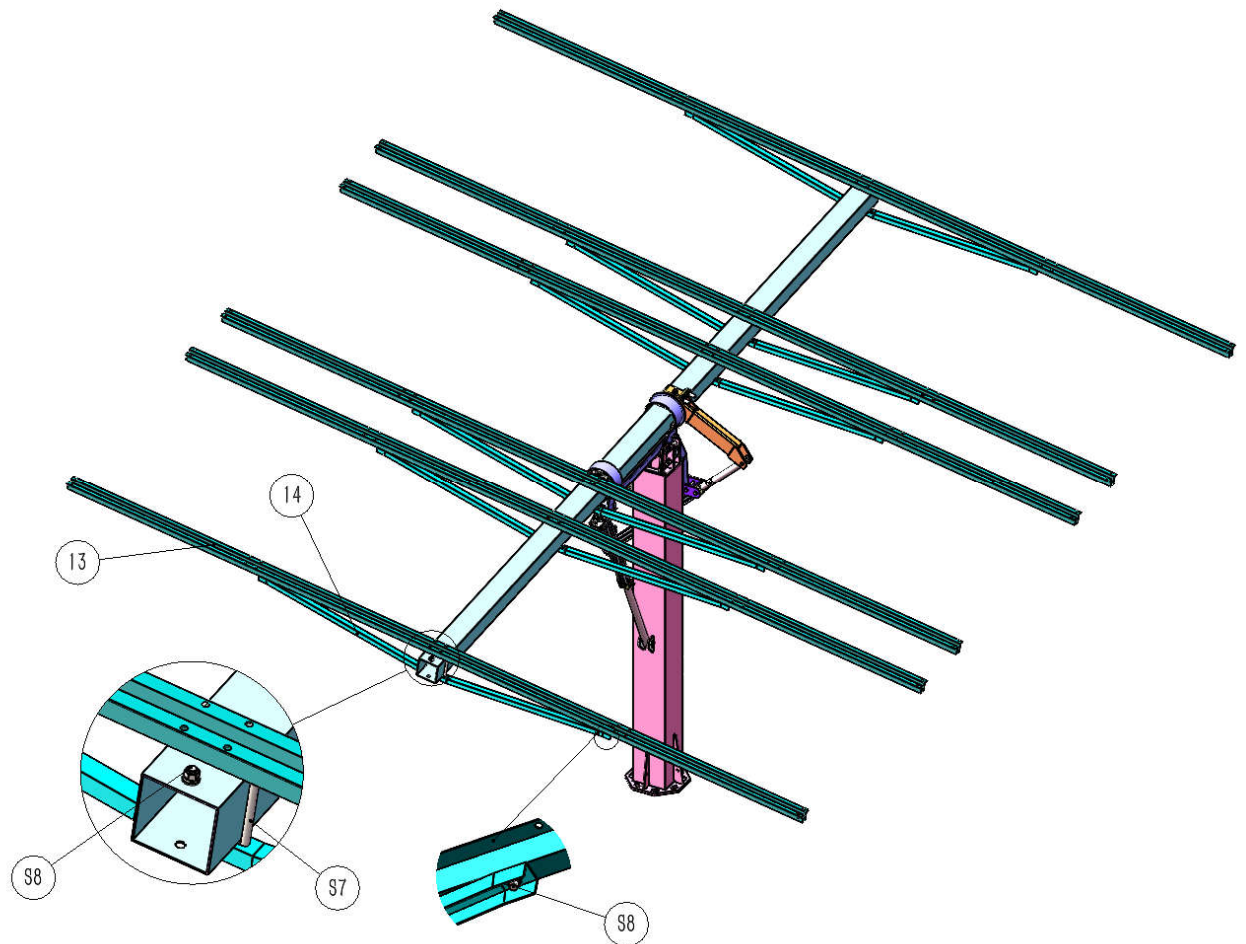

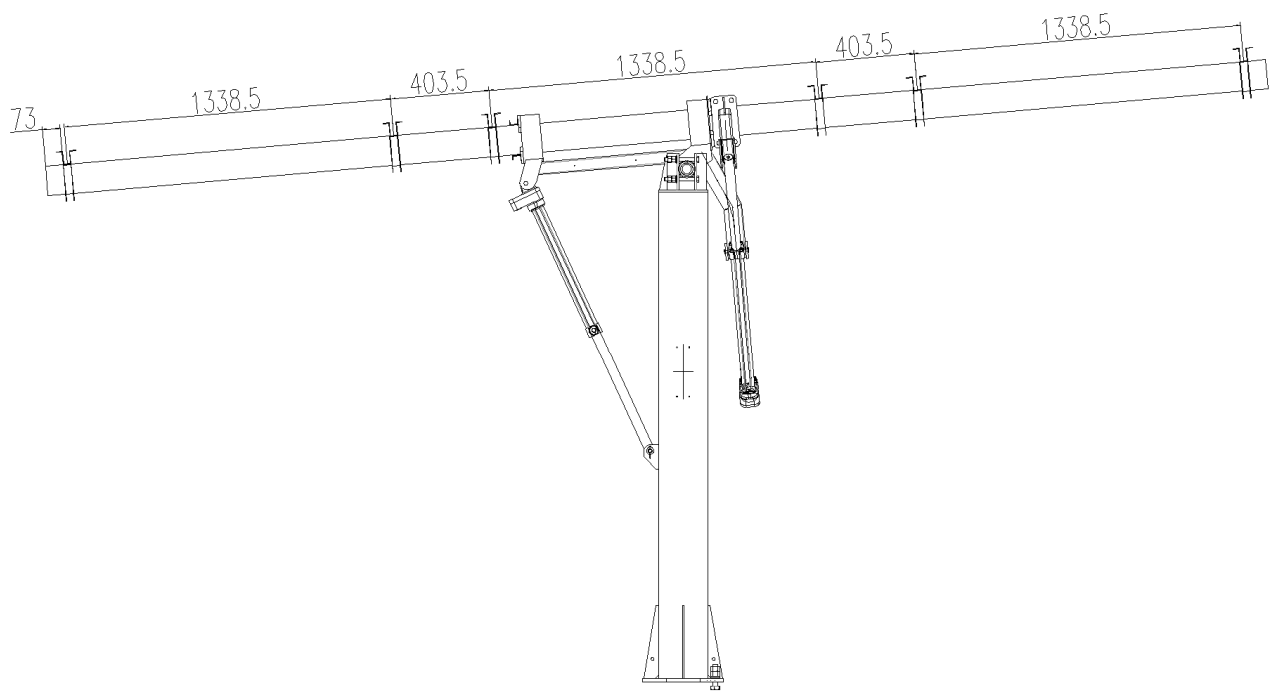

5.6 Installation of Control Unit

Fix the **control unit** (15) on the **vertical pole** with **hardware** S10, there are small holes on **vertical pole** for fixing control unit.

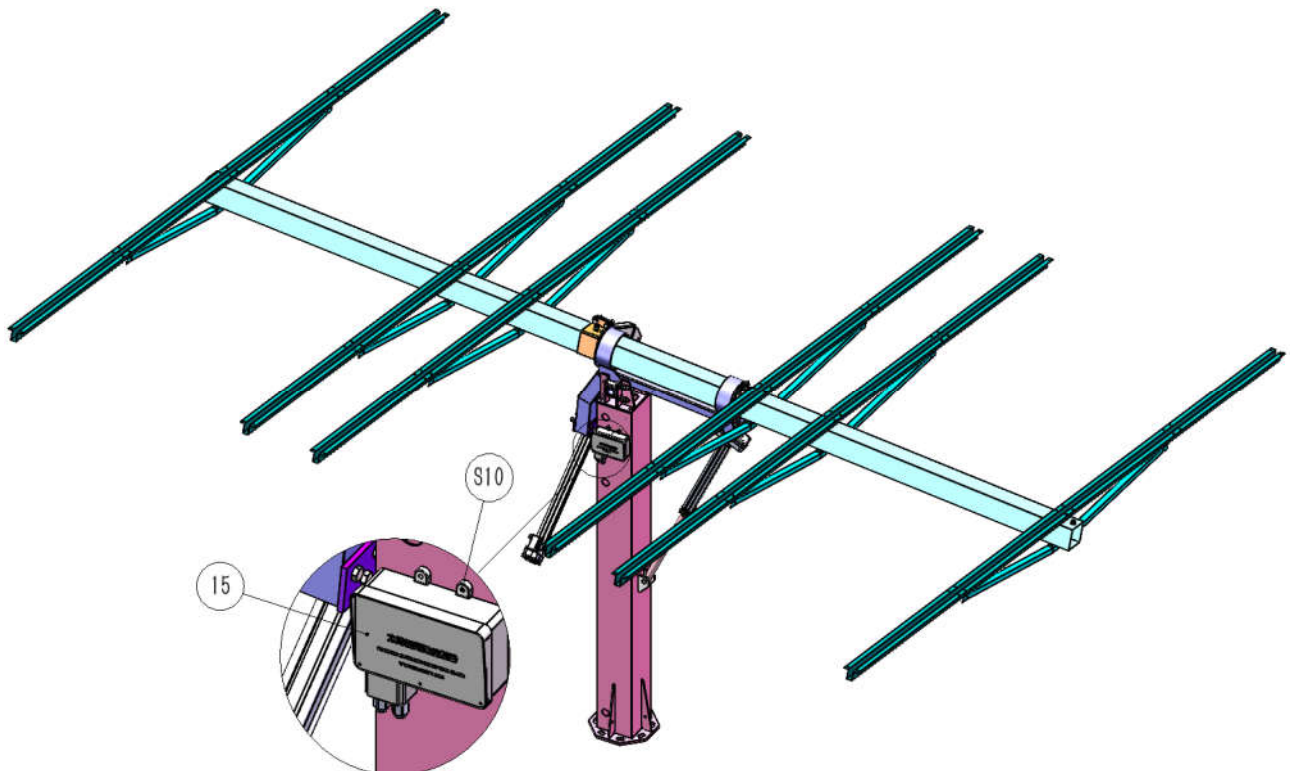

5.7 Installation of Solar Panels

Fix all the solar panels to the **supporting beam** with hardware **S9**.

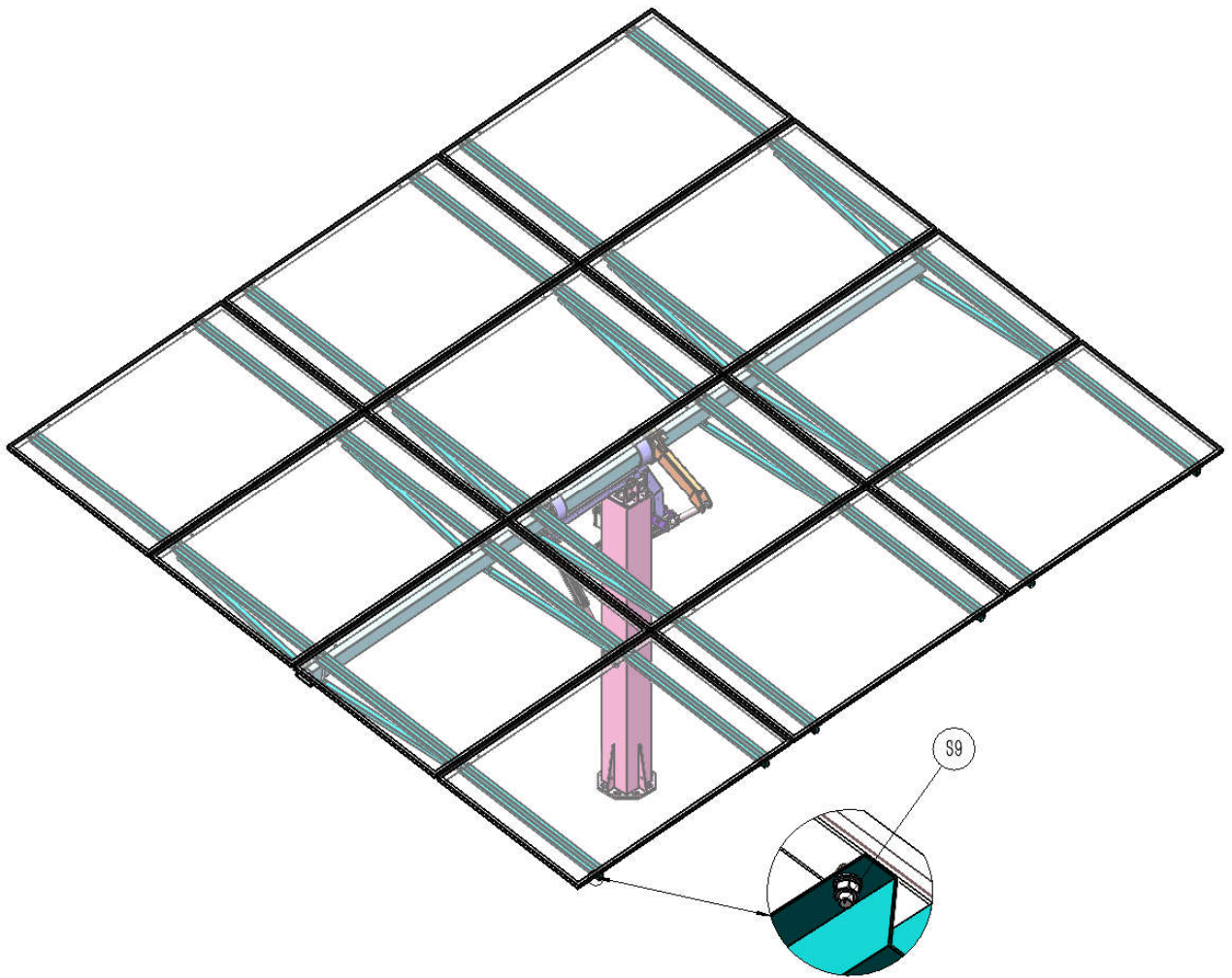

Note: after finished the installation of solar panels, please lock all of the connection screws.

There are reserved connecting holes at the bottom of vertical pole for lightning protection grounding, please grounding the brackets properly according to PV power station grounding standard in your country.

5.8 Connect Control Unit Circuit

Using A/C power supply

Connect **azimuth** motor cable (with label) with the motor on **azimuth** linear actuator, connect **elevation** motor cable (with label) with the motor on **elevation** linear actuator, **do not confuse the azimuth motor cable with the elevation motor cable**. Take off the small box on control unit, run A/C power from the cable holes of the small box, and connect the two power lines to the **power connectors**.

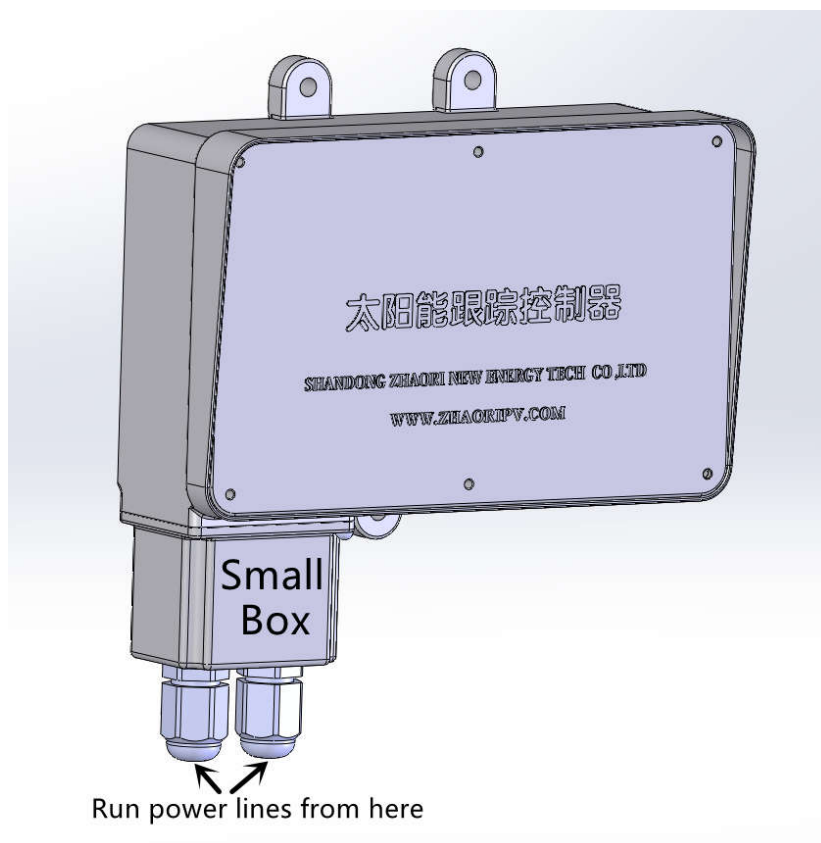



Use corrugated pipe (the blue part in the figure) and pipe clamp to fix the motor cable onto the vertical pole and L-shaped bracket, there are reserved small fixing holes on vertical pole and L-shaped bracket.

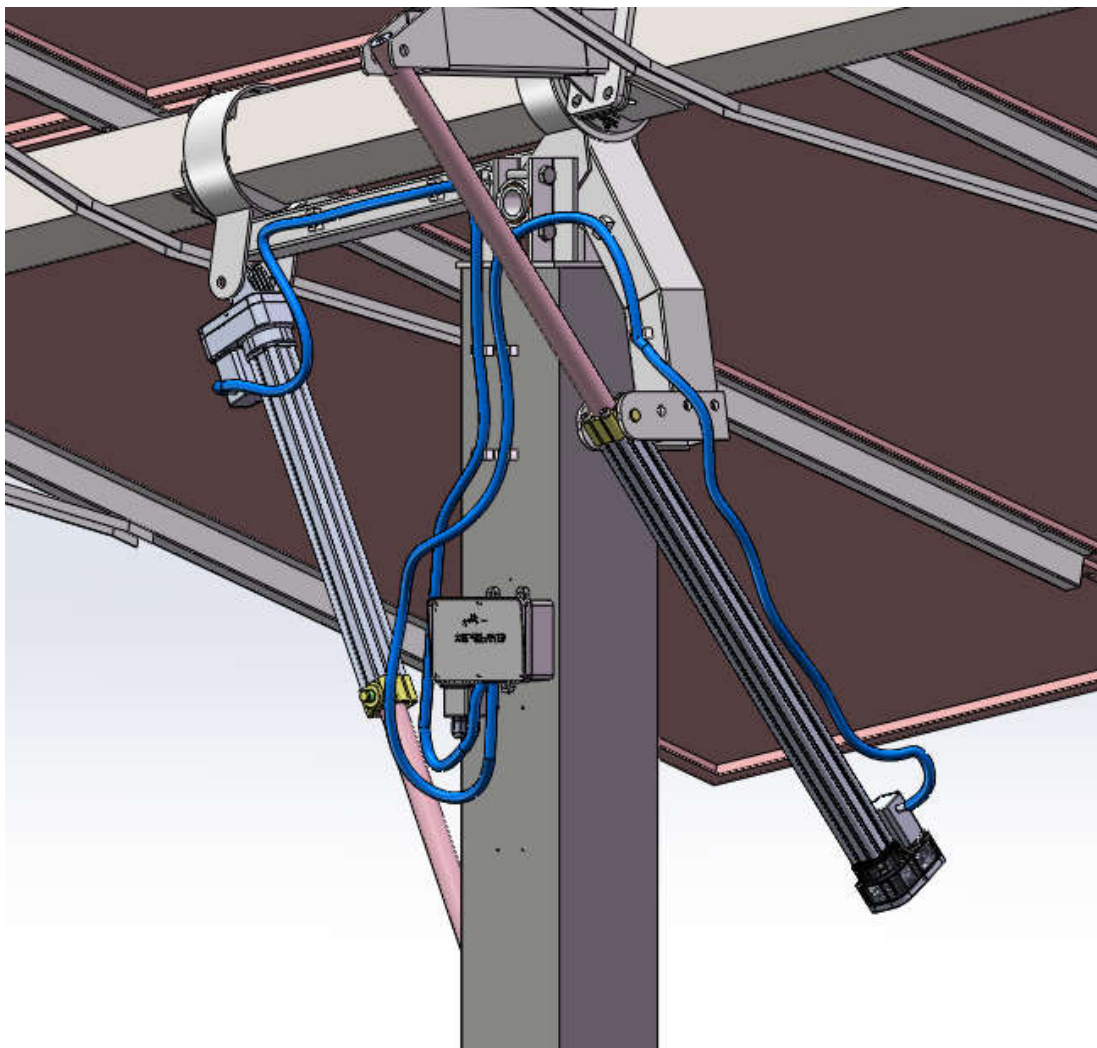

Installers can connect the wind sensor (if equipped) and rain/snow sensor (if equipped) to the sensor cable on **host control unit** with sensor wire.



Part VI: Crane Hoisting

If there is small crane equipped at the installation site, including the L-shaped bracket, azimuth linear actuator, frames and solar panels can be assembled in advance, then hoist it onto vertical pole ① directly, then following previous steps of 5.3 to fix the **L-shaped bracket** and **elevation linear actuator** and **control unit**.

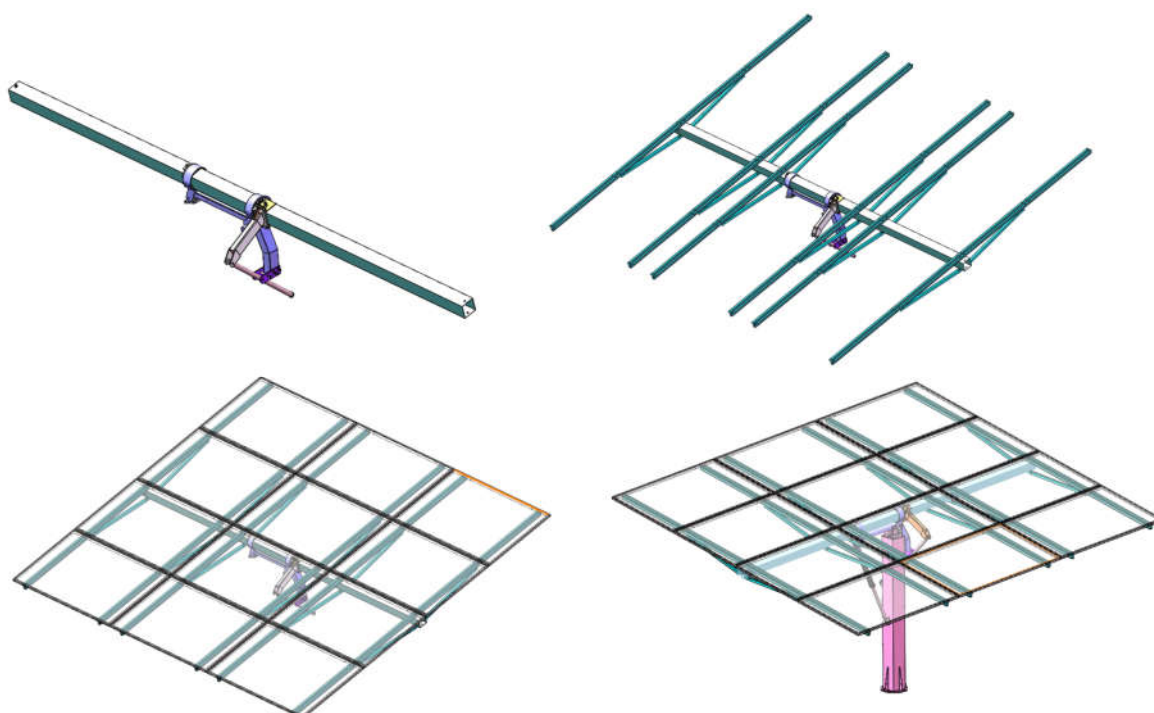

Part VII: Control Unit Debugging

Supply the A/C power to all of the driving systems in one project, the controller will automatically start after 5 minutes, and the host control unit will download GPS data automatically (need about 1 - 10 minutes), then the system will rotate to east or west and hit the angle limit position, then it will rotate to north or south and hit the angle limit position, then it will wait for a while and go to the right position automatically. **The slave driving systems will follow the movement of host driving system.**

Part VIII: Daily Operation and Maintenance – Important !

8.1 Regular inspection and maintenance

1. In order to discover potential fault timely, improve the system operation reliability, regular inspection shall be not less than once for every six months.
2. After bad weather like more than force 6 strong winds, tropical storm, heavy snow, or earthquake occurred, maintenance personnel should make a general checking for the bracket, repair it in time if there is any damage.

8.2 Inspection items and problem treatment

Item	Inspection content	Solutions
Bolts and nuts	Check whether bolts and nuts were loosed	If bolts and nuts were not well fastened during installation, or loosed due to strong winds, maintenance personnel need to re-fasten it.
Clamps	Check if clamps were deformed or loosed	If it was loosed because of screws were not well fastened, need to re-fasten the screws. If clamps were deformed, need to replace it.
Solar panels	Check whether solar panels are flat	If it's not flat and caused by structural distortion, need to rectify the distortion, or replace some parts. If it caused by loosed screws, need to re-fasten or replace the screws.
Brackets	Check whether there is any crack or rust problem	If it appears rust, should use abrasive paper for rust removing, then spary epoxy zinc-rich primer or other antifouling paint for protection. If cracks appear, consult with factory for solutions.
Wire connection in driving box	Check whether have loosed wire connection	If there is loosed wire connection, need re-connect it or replace the plugs.

Part IX: Quick Trouble Shooting

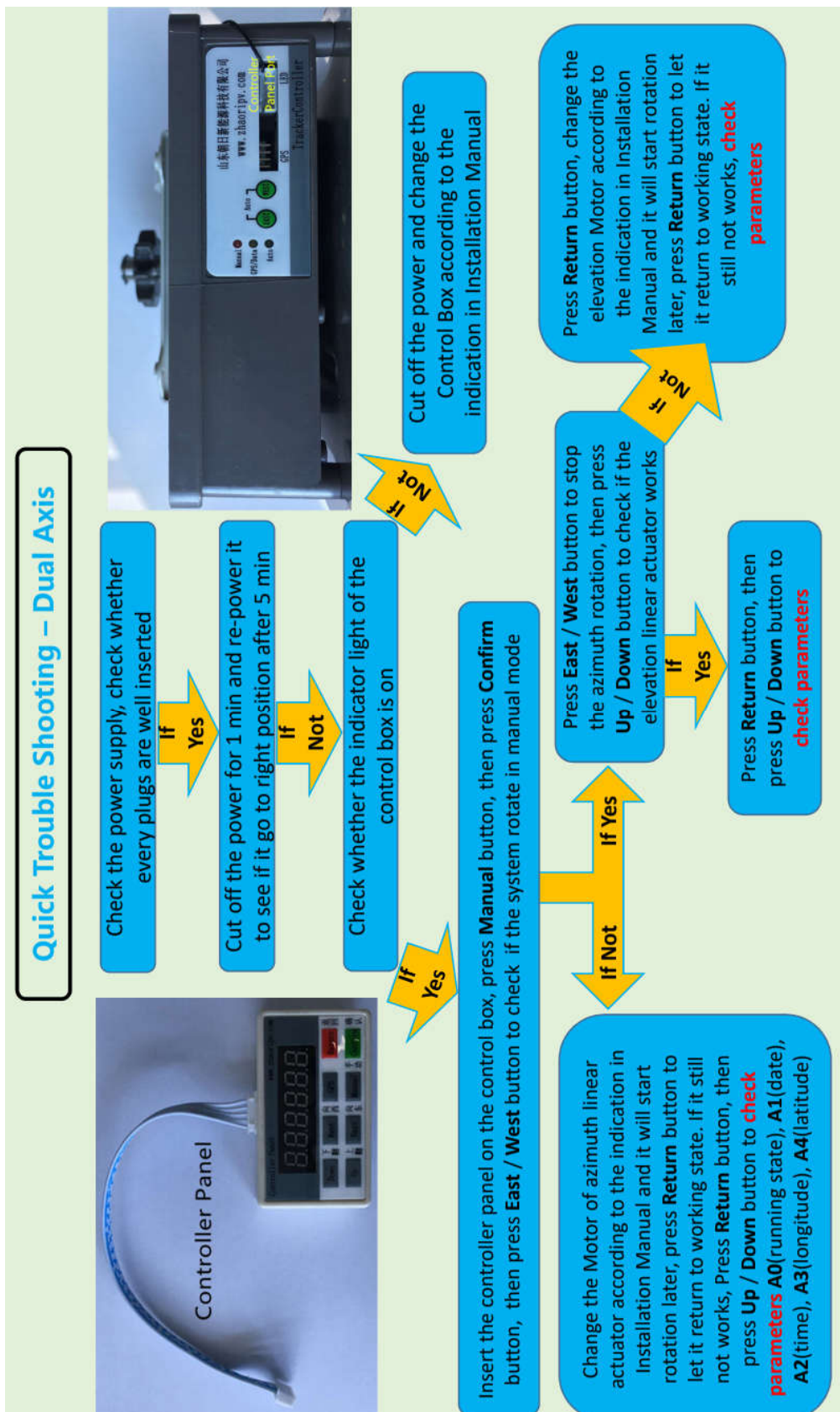

Please contact our customer service staff for situation not easy to judged and solved.

Part X: Spare Parts Replacement

Note: Cut off the power supply before replacement. If using PV power directly supply, disconnect all the connectors at input and output terminal of junction box or four-way connector. If using A/C power supply, cut off the A/C power switch.

10.1 Gear motor replacement

Unplug the gear motor plug, unscrew four fixing screws, take off the gear motor, apply sealant on a new motor, then fix the new motor with fixing screws, plug in the motor plug.

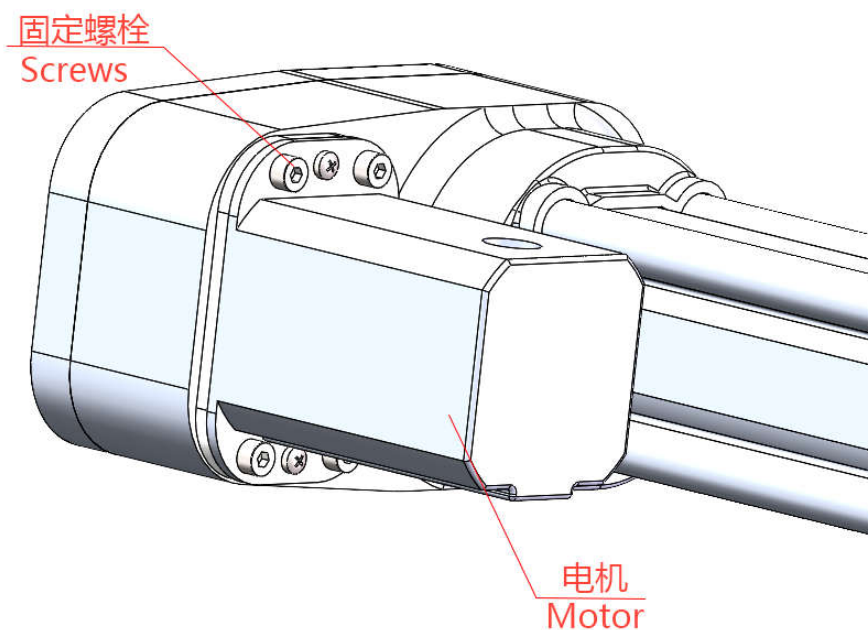

10.2 Control unit replacement

Open the small box on control unit, take off the power lines and motor cables, then fix a new control box with the fixing screws, and connect all plugs as before, fix the small box on control unit.

